

TAI / TAP SERIES ALUMINIUM THREE PHASE



0.06kW to 37kW – Frame 56 to 200L

Techtop's TAI/TAP aluminium series motors are suitable for all industrial applications where optimal design performance and low weight are key factors.



Operating parameters

Standard TAI/TAP series motors are designed with the following parameters:

- 380V to 415V, 50Hz & 440V to 480V, 60Hz supply
- Continuous (S1) duty
- Ambient temperatures up to 40°C
- Installation up to 1000 MASL

Connection

- 230V Delta / 400V Star (3kW & below)
- 400V Delta / 690V Star (4kW & above)

Standards

Dimensions and rated outputs for the TAI/TAP series conform to Australian Standard AS/NZS 1359 and International Standards IEC 60034 and IEC 60072.

Standard & High Efficiency

The TAI range complies with MEPS2 requirements of AS/NZS 1359.5:2004 Table A2 (**Standard Efficiency**). The TAP range complies with MEPS2 requirements of AS/NZS 1359.5:2004 Table A3 (**High Efficiency**). Motors are tested in accordance with Test Method A of AS/NZS 1359.102.3 as per IEC 60034-2-1.

Insulation class

TAI/TAP motors are insulated with Class F materials and limited to Class B temperature rise. The windings are spike resistant making them suitable for use with VVVF drives.

Thermistors

As standard all TAI/TAP series motors from 160 frame and above are fitted with one set of PTC thermistors. The thermistor termination is located in the main terminal box and has a trip temperature of 150°C as standard.

Additional 130°C thermistors can be fitted as an option for alarm connection. Thermistors are available as an option for smaller frame sizes.

IP Protection

The standard degree of enclosure protection for TAI series is IP 55 (increased IP protection is available). Shafts are fitted with an oil seal as standard on flange mount and a V ring seal on foot mount.

TAP series are IP66 as standard and are fitted with oil seals on both ends.

Multi-mount design

As standard, TAI/TAP series motors are fitted with detachable feet. The multi-mount design allows for the motor feet to be removed and repositioned to either side to produce a side mounted terminal box.

Alternatively the feet can be removed and the motor mounted from any of the 16 mounting pads.

Fan & Gearbox application

TAI/TAP series motors are low weight design and come standard a drilled and tapped hole in the shaft which makes this series ideal for fan applications. This motor series is also ideally suited for fitting to aluminium gearboxes. *Optional B5R flange is available for gearbox fitment – B5R flanges are one frame size smaller than standard B5 flanges.

Terminal box

The terminal box is manufactured from aluminium and is mounted on top of the motor as standard. Terminal box is separate to the motor body and can be rotated in 90° increments..

Surface Finish

As standard TAI/TAP motors are powder coat finish with final colour being RAL 9005 Jet Black. Other colours are available upon request.

Bearings

Bearings fitted are high quality NSK deep groove ball bearings that are sealed for life.

Frame size	Bearing	
	Aluminium	N.D.E
56	6201 ZZ	
63	6202 ZZ	
71	6202 ZZ	
80	6204 ZZ	
90	6205 ZZ	
100	6206 ZZ	
112	6306 ZZ	6206 ZZ
132	6308 ZZ	6208 ZZ
160	6309 ZZ	6209 ZZ
180	6311 ZZ	6211 ZZ
200	6312 ZZ	6212 ZZ

Conduit Entries

Frame Size	Entry Size	Number of Entries
56	M20 x 1.5	1
63	M20 x 1.5	1
71	M20 x 1.5	1
80	M25 x 1.5	2
90	M25 x 1.5	2
100	M20 x 1.5	2
112	M25 x 1.5	2
132	M25 x 1.5	2
160	M32 x 1.5	2
180	M32 x 1.5	2
200	M50 x 1.5	2

Part Number Logic

Detailed below is the part number logic which should be specified when placing orders. The part number is composed in accordance with the following example:

T	A	4	B	0	2	2	5	TAI	B
1	2	3	4	5 - 7			8	9 - 12	13 - 15

Position 1

T = Techttop

Position 2

A = Aluminium

C = Cast Iron

Position 3

2 = 2 Pole

4 = 4 Pole

6 = 6 Pole

8 = 8 Pole

Position 4

A = less than 0.99kW

B = 1.0kW to 9.9kW

C = 10.0kW to 99.9kW

Position 5 to 7

Output kW

Position 8

Mounting position

1 = V1

3 = B3

4 = B3/5

5 = B5

6 = B3/B14A

7 = B14A

8 = B3/B14B

9 = B14B

A = B5R

B = B3/B5R

Position 9 to 12

TAI = Aluminium Std Eff.

TAP = Aluminium Hi-Eff.

Position 13 to 15

BHR = Brake motor with hand release

H = Class H insulation



TAI SERIES PERFORMANCE DATA

Output kW	Full Load Speed [RPM]	Frame Size	Shaft Diam. [mm]	Current @400v		Efficiency		Power Factor		Torque				Noise Level dB (A)	Weight Foot Mount [Kg]
				Full Load [A]	Locked Rotor [%]	Full Load [%]	3/4 Load [%]	Full Load [%]	3/4 Load [%]	Full Load [Nm]	Locked Rotor [% FLT]	Pull Up [% FLT]	Break Down [% FLT]		
0.06	1370	56A	9	0.30	314	50.9	46.6	0.56	0.48	0.42	320	302	319	56	2.9
	2715	56A	9	0.32	329	53.5	49.6	0.76	0.65	0.32	228	212	239	58	2.6
	1375	56B	9	0.41	315	52.6	48.7	0.60	0.51	0.62	285	259	280	56	3.2
	840	63A	11	0.43	250	46.3	44.1	0.65	0.55	1.01	213	197	208	54	4.2
0.09	665	71A	14	0.53	233	43.1	38.7	0.57	0.50	1.29	241	235	257	52	5.6
	2700	56B	9	0.36	378	61.6	60.6	0.79	0.68	0.43	249	213	234	58	3.0
	1300	63A	11	0.51	292	54.6	52.1	0.62	0.52	0.88	302	272	279	55	3.7
	830	63B	11	0.56	237	48.0	46.5	0.65	0.55	1.38	219	190	205	54	4.5
0.12	650	71B	14	0.62	259	47.7	44.5	0.59	0.50	1.75	252	247	262	52	6.0
	2710	63A	11	0.55	375	60.7	58.6	0.78	0.66	0.63	244	207	236	58	4.0
	1275	63B	11	0.67	288	56.8	57.3	0.68	0.57	1.35	234	217	228	56	3.7
	880	71A	14	0.66	291	57.8	56.4	0.68	0.57	1.95	227	209	224	55	5.6
0.18	690	80A	19	0.82	291	55.0	51.4	0.58	0.49	2.48	223	202	248	53	8.3
	2715	63B	11	0.71	394	65.6	64.4	0.78	0.67	0.88	271	196	232	60	4.2
	1365	71A	14	0.75	388	63.0	61.7	0.76	0.68	1.74	205	184	224	58	5.0
	850	71B	14	0.84	293	59.7	61.2	0.72	0.61	2.79	195	187	205	56	6.0
0.25	680	80B	19	1.05	307	58.7	55.6	0.58	0.49	3.46	230	207	248	54	9.3
	2770	71A	14	1.04	503	62.8	60.5	0.82	0.73	1.28	288	188	257	61	5.2
	1370	71B	14	1.03	428	67.2	66.3	0.77	0.66	2.60	229	190	228	60	5.8
	900	80A	19	1.32	318	61.2	58.8	0.66	0.55	3.89	197	189	227	56	7.8
0.37	700	90S	24	1.41	309	64.4	61.5	0.59	0.50	4.98	195	176	225	53	11.4
	2800	71B	14	1.41	504	71.3	69.9	0.79	0.69	1.88	302	181	269	61	6.0
	1380	71C	14	1.47	424	66.0	66.5	0.70	0.64	3.84	231	191	218	57	7.1
	1410	80A	19	1.63	449	71.5	70.1	0.68	0.58	3.72	233	190	259	59	8.3
0.55	900	80B	19	1.85	346	65.8	64.4	0.65	0.54	5.79	217	198	234	58	9.1
	700	90L	24	2.1	338	65.3	62.9	0.58	0.49	7.46	195	179	235	57	13.9
	2880	80A	19	1.76	687	80.1	80.2	0.79	0.71	2.5	292	196	302	64	9.5
	1420	80B	19	1.94	550	81.1	81.5	0.69	0.60	5.0	303	270	310	60	10.5
0.75	930	80C	19	2.21	448	76.3	75.9	0.64	0.54	7.7	311	271	296	59	12.3
	940	90S	24	2.22	444	76.3	75.7	0.65	0.54	7.6	225	196	252	58	13.0
	690	100LA	28	2.21	363	72.3	73.3	0.68	0.58	10.4	177	175	213	55	21.0
	2880	80B	19	2.39	758	81.2	81.3	0.82	0.74	3.6	283	186	285	64	10.4
1.1	1430	80C	19	2.73	637	82.3	82.6	0.71	0.62	7.3	309	263	321	61	12.3
	1420	90S	24	2.57	618	82.8	83.8	0.75	0.67	7.4	296	247	297	60	14.3
	950	90L	24	2.98	487	78.4	78.7	0.69	0.60	11.0	207	180	245	59	16.0
	690	100LA	28	3.17	390	74.8	75.2	0.67	0.57	15.1	198	192	230	55	25.0
1.5	2880	90S	24	3.19	690	83.1	83.5	0.83	0.75	5.0	276	187	308	68	13.5
	1440	90L	24	3.35	713	85.5	86.1	0.76	0.68	9.9	316	240	313	60	18.0
	945	100LA	28	3.71	472	80.1	82	0.74	0.66	15.1	172	161	225	66	20.0
	700	112M	28	4.18	403	78.4	79.3	0.68	0.59	20.4	182	180	212	55	25.4
2.2	2890	90L	24	4.61	811	84.0	84.4	0.83	0.75	7.2	300	222	318	68	16.2
	1430	90LB	24	5.02	769	84.3	85.3	0.76	0.66	14.7	426	342	403	60	18.8
	1440	100LA	28	4.55	726	85.8	86.6	0.82	0.76	14.6	260	218	305	62	23.4
	950	112M	28	5.36	547	82.8	83.9	0.73	0.64	22.0	220	181	271	66	26.3
3	710	132S	38	5.95	420	80.0	80.6	0.67	0.58	29.4	186	174	233	55	44.0
	2900	100L	28	5.59	920	87.0	87.6	0.90	0.87	9.9	309	249	351	78	22.3
	1445	100LB	28	6.27	760	86.0	86.6	0.80	0.73	19.8	239	244	325	62	26.3
	960	132S	38	6.42	601	85.5	86.6	0.76	0.70	29.6	188	157	258	58	43.0
4	715	132M	38	7.8	529	82.7	83.1	0.70	0.61	39.9	231	203	274	58	51.0
	2915	112M	28	7.56	960	87.4	87.7	0.89	0.84	13.1	332	208	365	78	28.7
	1440	112M	28	8.17	781	87.5	88.2	0.82	0.75	26.4	257	231	335	73	35.2
	960	132MA	38	9.21	583	84.7	85.6	0.74	0.68	39.6	200	165	257	58	52.0
5.5	710	160MA	42	9.90	477	83.5	84.5	0.70	0.61	53.5	189	172	240	58	60.0
	2920	112MB	28	10.3	1014	88.6	88.9	0.87	0.82	18.0	349	281	411	71	30.0
	2910	132SA	38	10.3	823	87.8	88.3	0.89	0.85	18.0	244	195	343	69	45.4
	1435	112MB	28	11.3	829	87.9	88.8	0.80	0.73	36.6	378	319	359	66	37.0
7.5	1460	132S	38	11.0	856	88.1	88.5	0.83	0.77	35.9	217	193	350	63	49.4
	960	132MB	38	12.4	654	86.3	87.5	0.75	0.69	54.5	240	184	261	58	58.5
	715	160MB	42	13.3	505	85.1	86.1	0.70	0.62	73	209	185	263	64	82.0
	2920	132SB	38	13.9	1029	89.2	89.6	0.89	0.86	24.5	314	202	366	69	50.0
9.2	1450	132M	38	14.3	823	89.5	90.4	0.85	0.82	49.4	299	117	295	63	62.3
	960	160M	42	16.0	688	87.7	88.7	0.77	0.70	74.1	257	187	288	61	74.0
	710	160L	42	17.6	596	86.5	87.4	0.71	0.63	99.9	271	158	295	64	92.0
9.2	1455	132MB	38	17.4	870	89.5	90.4	0.85	0.81	49.4	295	171	312	63	60.1

TAI / TAP SERIES

TAI SERIES PERFORMANCE DATA CONTINUED

Output kW	Full Load Speed [RPM]	Frame Size	Shaft Diam. [mm]	Current @400v		Efficiency		Power Factor		Torque				Noise Level dB (A)	Weight Foot Mount [Kg]
				Full Load [A]	Locked Rotor [%]	Full Load [%]	3/4 Load [%]	Full Load [%]	3/4 Load [%]	Full Load [Nm]	Locked Rotor [% FLT]	Pull Up [% FLT]	Break Down [% FLT]		
11	2930	132MB	38	19.5	1261	90.8	91.0	0.90	0.86	35.8	402	243	390	69	58.5
	2945	160MA	42	19.7	831	90.5	90.6	0.89	0.86	35.6	267	152	345	75	79.0
	1460	132MC	38	20.6	922	90.5	91.2	0.85	0.81	71.9	331	148	353	63	68.0
	1460	160M	42	21.3	698	89.7	90.5	0.83	0.79	71.8	254	176	279	67	83.0
	970	160L	42	23.4	641	89.4	90.0	0.76	0.70	108.2	228	131	239	61	93.0
	730	180L	48	24.1	637	89.2	89.6	0.74	0.67	143.6	201	180	273	64	129
15	2950	160MB	42	26.0	939	92.5	92.7	0.90	0.86	48.5	260	186	343	75	91.0
	1460	160L	42	28.2	829	91.4	91.9	0.84	0.80	97.6	251	164	288	67	102
	975	180L	48	29.2	768	90.4	90.9	0.82	0.78	146.8	242	170	283	61	130
	730	200L	55	31.9	723	90.6	91.0	0.75	0.68	195.6	263	205	318	66	168
18.5	2950	160L	42	31.9	978	91.9	91.2	0.91	0.88	59.9	325	186	338	75	103
	1460	180M	48	33.2	774	91.5	91.9	0.88	0.83	120.4	238	185	298	67	119
	980	200LA	55	36.9	853	91.2	91.2	0.81	0.74	179.4	207	139	320	63	149
22	2950	180M	48	39.5	865	92.3	92.6	0.87	0.85	71.2	274	160	316	75	128
	1460	180L	48	39.4	768	91.7	92.3	0.88	0.84	143.4	242	170	283	67	129
	980	200LB	55	42.6	1031	91.9	92.1	0.83	0.78	213.5	313	156	342	63	162
30	2955	200LA	55	52.9	703	92.0	92.3	0.90	0.88	96.9	205	104	254	75	158
	1470	200L	55	54.2	946	92.9	93.2	0.86	0.82	194.5	325	233	370	70	169
37	2950	200LB	55	63.7	954	92.1	91.8	0.91	0.89	119.5	287	134	348	75	182

TAP SERIES PERFORMANCE DATA

Output kW	Full Load Speed [RPM]	Frame Size	Shaft Diam. [mm]	Current @400v		Efficiency		Power Factor		Torque				Noise Level dB (A)	Weight Foot Mount [Kg]
				Full Load [A]	Locked Rotor [%]	Full Load [%]	3/4 Load [%]	Full Load [%]	3/4 Load [%]	Full Load [Nm]	Locked Rotor [% FLT]	Pull Up [% FLT]	Break Down [% FLT]		
0.75	2890	80A	19	1.64	735	81.6	81.3	0.81	0.72	2.5	315	235	324	64	8.4
	1435	80B	19	1.81	618	83.1	83.4	0.72	0.64	5.0	288	241	296	60	11.3
	945	90S	24	2.01	469	80.0	80.3	0.67	0.58	7.5	231	211	267	58	14.0
1.1	2900	80B	19	2.38	809	83.1	82.6	0.80	0.72	3.6	341	262	351	64	10.2
	1440	90S	24	2.58	674	84.9	85.4	0.72	0.64	7.3	308	248	312	60	15.0
	950	90L	24	2.94	519	81.0	81.1	0.67	0.57	11.1	278	250	298	59	16.2
1.5	2895	90S	24	3.11	825	84.9	85.0	0.82	0.74	4.9	351	210	373	68	14.4
	1440	90L	24	3.60	722	85.7	86.0	0.70	0.61	9.9	385	294	367	60	18.0
	945	100LA	28	3.55	504	82.4	83.8	0.74	0.66	15.1	214	209	262	59	22.0
2.2	2895	90L	24	4.49	808	86.5	86.9	0.82	0.74	7.2	312	226	360	68	16.2
	1450	100LA	28	4.45	793	87.2	87.8	0.82	0.75	14.5	296	248	355	62	23.4
	950	112M	28	5.54	543	84.6	85.3	0.68	0.60	22	208	188	254	59	26.0
3	2915	100L	28	5.60	933	87.4	87.9	0.89	0.84	9.8	318	262	360	71	24.1
	1450	100LB	28	6.20	829	88.2	88.7	0.79	0.71	19.7	339	291	378	62	28.0
	965	132S	38	6.80	593	85.9	86.9	0.74	0.67	29.6	200	175	271	63	39.0
4	2925	112M	28	7.22	1051	88.1	88.5	0.91	0.87	13.1	347	249	398	71	30.2
	1450	112M	28	7.93	854	88.8	89.4	0.82	0.75	26.3	309	266	374	66	32.2
	970	132MA	38	8.88	678	87.4	88.1	0.74	0.67	39.3	237	183	304	63	47.2
5.5	2930	132SA	38	9.98	991	89.5	89.7	0.89	0.85	17.9	318	249	402	69	44.1
	1460	132S	38	10.5	898	89.8	90.5	0.84	0.79	35.9	231	198	350	63	48.0
	970	132MB	38	12.6	738	88.3	88.7	0.71	0.63	53.9	289	220	348	58	55.4
7.5	2925	132SB	38	13.0	1005	90.6	91.4	0.92	0.90	24.5	265	191	362	69	52.0
	1460	132M	38	13.9	889	90.5	91.3	0.86	0.81	49.4	288	175	350	63	58.4
	975	160M	42	15.9	727	89.6	90.3	0.76	0.70	73.5	221	187	297	61	79.6
11	2960	160MA	42	19.7	831	91.9	91.7	0.88	0.84	35.5	267	152	345	75	85.5
	1470	160M	42	20.7	756	92.3	92.8	0.83	0.79	71.4	263	183	299	67	89.0
	975	160L	42	22.2	838	90.9	91.6	0.79	0.73	107.5	279	124	291	61	105
15	2965	160MB	42	26.3	1140	92.4	92.0	0.89	0.85	48.3	392	140	427	75	104
	1470	160L	42	27.6	914	92.6	93.0	0.85	0.81	97.3	300	158	296	67	111
	980	180L	48	30.4	817	91.0	91.0	0.78	0.72	146.8	258	217	339	61	140
18.5	2945	160L	42	31.6	903	92.5	93.2	0.91	0.88	59.9	304	150	301	75	121
	1470	180M	48	33.5	872	92.5	92.8	0.86	0.82	119.9	289	196	333	67	125
	980	200LA	55	36.4	980	91.7	91.5	0.80	0.79	180.3	270	198	370	63	143
22	2950	180M	48	37.5	869	92.7	93.2	0.91	0.9	71.1	274	160	316	75	135
	1475	180L	48	39.3	923	93.4	93.5	0.86	0.81	142.4	306	218	359	67	145
	980	200LB	55	43.1	1050	92.2	92.0	0.80	0.78	214.4	290	220	370	63	162
30	2960	200LA	55	51.2	1012	93.7	93.5	0.90	0.88	96.7	358	189	384	75	165
	1470	200L	55	52.6	968	93.8	94.0	0.88	0.83	194.4	328	216	372	70	175
37	2960	200LA	55	63.4	980	93.7	93.6	0.90	0.88	119.4	360	173	370	75	173



TAI / TAP SERIES MOTOR OUTLINE DIMENSIONS

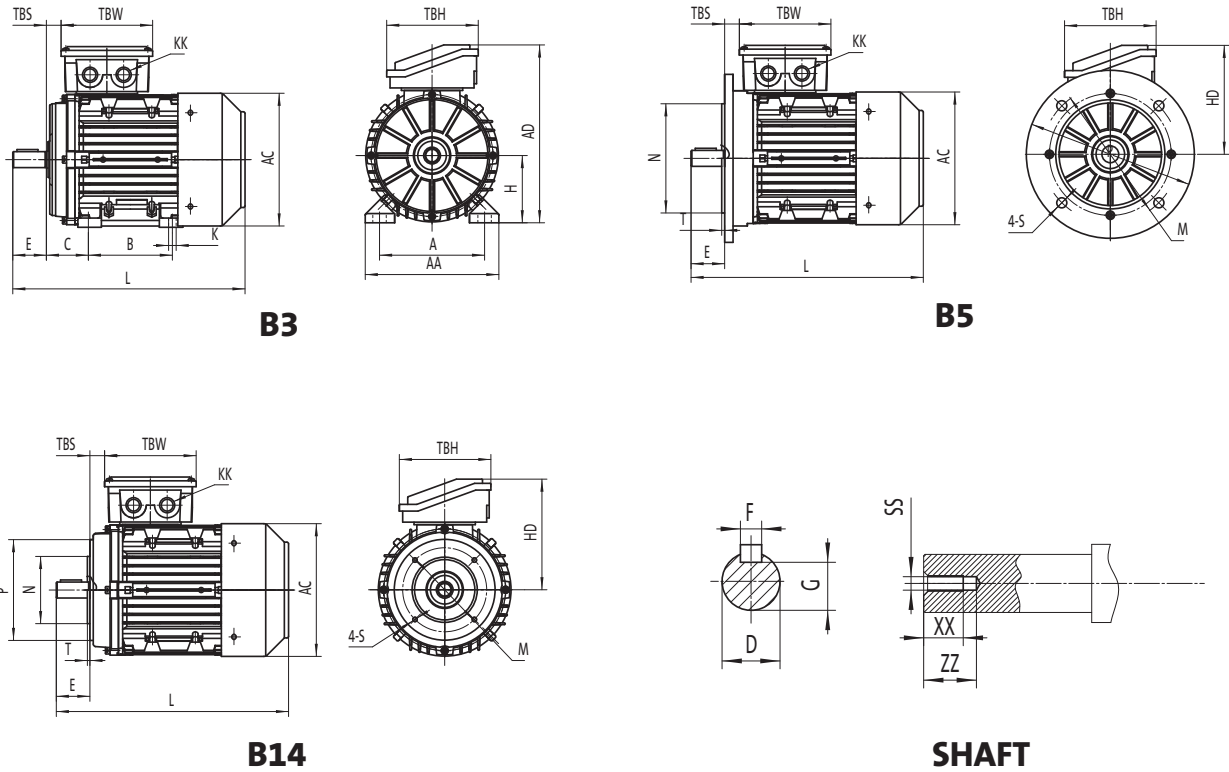

TAI / TAP SERIES DIMENSIONAL DATA

FRAME	Foot Mounting				Shaft								General							
	H	A	B	C	D	E	F	G	K	SS	XX	ZZ	AA	AD	HD	AC	L	TBS	TBW	TBH
TAI 56	56	90	71	36	9	20	3	7.2	6	M3	9	12	112	150	94	110	195	16.5	83	83
TAI 63	63	100	80	40	11	23	4	8.5	7	M4	10	14	124	169	106	122	215	10	98	98
TAI 71	71	112	90	45	14	30	5	11	7	M5	12	17	140	185	114	138	245	16	98	98
TAI 80	80	125	100	50	19	40	6	15.5	9	M6	16	21	160	214	134	158	280	18.5	109	109
TAI 90S/L	90	140	100/125	56	24	50	8	20	10	M8	19	25	175	233	143	177	315/340	20.5	109	109
TAI 100L	100	160	140	63	28	60	8	24	12	M10	22	30	200	260	160	200	377	29	118	118
TAI 112M	112	190	140	70	28	60	8	24	12	M10	22	30	230	283	171	220	400	30	118	118
TAI 132S/M	132	216	140/178	89	38	80	10	33	12	M12	28	37	255	322	190	261	460/498	34	118	118
TAI 160M/L	160	254	210/254	108	42	110	12	37	15	M16	36	45	314	391	231	313	616/662	64	148	148
TAI 180M/L	180	279	241/279	121	48	110	14	42.5	15	M16	36	45	340	440	260	368	730	73	190	190
TAI 200L	200	318	305	133	55	110	16	49	19	M20	42	53	390	460	260	368	745	85	190	190

FRAME	B5					B14A					B5R					B14B					
	N	M	P	S	T	N	M	P	S	T	N	M	P	T	S	N	M	P	T	S	
TAI 56	80	100	120	4-7	3	50	65	80	M5	2.5											
TAI 63	95	115	140	4-10	3	60	75	90	M5	2.5											
TAI 71	110	130	160	4-10	3.5	70	85	105	M6	2.5	95	115	140	3	10	95	115	140	3	M8	
TAI 80	130	165	200	4-12	3.5	80	100	120	M6	3	110	130	160	3.5	10	110	130	160	3.5	M8	
TAI 90	130	165	200	4-12	3.5	95	115	140	M8	3	110	130	160	3.5	10	110	130	160	3.5	M8	
TAI 100	180	215	250	4-15	4	110	130	160	M8	3.5	130	165	200	3.5	12	130	165	200	3.5	M10	
TAI 112	180	215	250	4-15	4	110	130	160	M8	3.5	130	165	200	3.5	12	130	165	200	3.5	M10	
TAI 132	230	265	300	4-15	4	130	165	200	M10	3.5	180	215	250	4	15	180	215	250	4	M12	
TAI 160	250	300	350	4-19	5	180	215	250	M12	4											
TAI 180	250	300	350	4-19	5																
TAI 200	300	350	400	4-19	5																