

marathon[™]
CMG Motors

CWT series
special applications
& general purpose motors

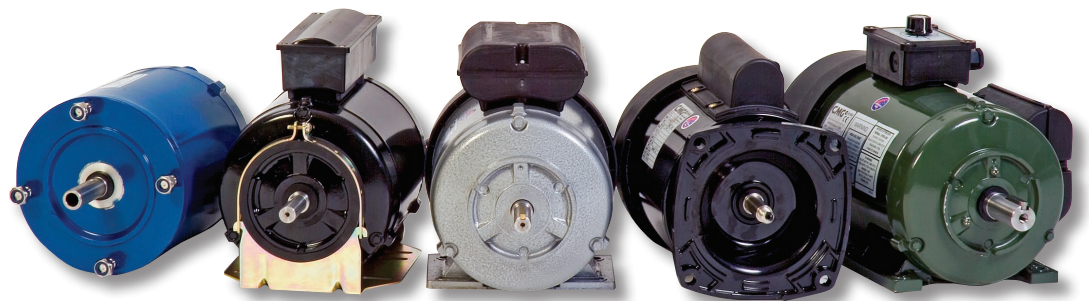

A Regal Brand

REGAL

“We convert power into motion to help the world run more efficiently”

BUSINESS PURPOSE

ABOUT US

Regal Beloit Corporation is a leading manufacturer of electric motors, mechanical and electrical motion controls and power generation products serving markets throughout the world. Regal Beloit is headquartered in Beloit, Wisconsin, and has manufacturing, sales and service facilities throughout the United States, Canada, Mexico, Europe and Asia.

Regal Australia brings together the strength and experience of three of Australia’s leading suppliers of engineered industrial products. CMG, OBA and Transmission Australia are now in a position to offer industry an unparalleled range of products under the Regal Australia banner.

Our products are efficient and innovative; they conform to Australian design, performance and engineering standards. Regal Australia sources products from Regal manufacturing facilities and represents some of the world’s leading industrial manufactures.

Regal Australia embraces the company core values of Integrity, High Energy and Performance and has adopted the initiatives of customer care, globalization, innovation, sustainability and simplification.

Our company business statement is that “We convert power into motion to help the world run more efficiently” has direct lineage to our core values and initiatives.

REGAL

OUR CORE VALUES



Integrity

We are a company that is honest, trustworthy, candid, transparent and fair.

High Energy

Our culture promotes a strong work ethic with high energy teams fostering a culture of inclusion and respect for all.

Performance

Everyone is expected to perform and our stakeholders count on us to execute, meet commitments and continuously improve.

REGAL

OUR INITIATIVES



Customer Care

Our future depends on the success of our customers. We will establish closer relationships with our customers, actively listen to their feedback and respond with a sense of urgency.



Globalization

We want to be global for three reasons. First, we want to participate in high growth markets around the world. Second, many of our customers are global and we want to serve customers where they do business. Finally, we want to utilize our global capabilities to seek out the best talent and to remain globally competitive.



Innovation

We will build the future of the Company on products that are new and needed. While we accept that with an innovation headset comes a certain degree of risk, we are committed to investing in new products, technologies and processes that deliver real value to our customers.



Sustainability

The long term sustainability of our Company requires not only continuous growth and profitability, but also that we take personal responsibility for the impact we have on our planet, and for the fair and just treatment of the people we employ.



Simplification

Complexity is a serious disadvantage in business. We aim to simplify every aspect of our operations to eliminate complexities in order to increase our speed, improve our flexibility and reduce our costs.

TABLE OF CONTENTS

Features	4
Applications	5
Speedmaster Integral Motor-Drive	6
Evaporative Cooler Motors	7
Compressor Duty Motors	8
Bricksaw Motors	9
Cement Mixer / Split Phase Motors	10
Fan Series Motors	11
Grain Feeder Motors	12
Sewage Aeration Motors	13
General Purpose Motors	14
Pumping Motors	15
Brake Motors	16
Spare Parts	17
Application Dimensions	18
Performance Data (Standard Products)	20
Dimensions (Standard Products)	21
Technical Data	22

FEATURES

The CWTC special application motor range by Regal Australia offers complete customisation to suit your application needs. CWTC motors are designed and tested by our experienced engineering team, allowing for rapid prototyping.

The motors are manufactured in our modern Regal facility, using state of the art machines and production techniques.

Complimentary to the CWTC special application range is the general purpose CWT range of standard motors.

VERSATILE COMPONENTS

The success of the CWTC range is based around its configurable mechanical and electrical components which can be combined to match the needs of your application.

Terminal, capacitor, and other switch boxes offer many possibilities for electrical connection. The standard terminal box offers four lead entry points, two cable clamps, plus two conduit entries. Special shaft designs, and materials including stainless steel, are available on request.

MOUNTING OPTIONS

The CWTC range can be designed in all standard motor mounting arrangements and combinations including foot (B3), flange (B5), foot/flange (B3/B5), face (B14), and foot/face (B3/B14).

Special mounting requirements can also be accommodated, including pad mounting, resilient mounting, and special endshields with mounting studs and screws.

SURFACE FINISH

A full spectrum of colours is possible. Popular colours include Hammertex Grey (standard CWT range), Royal Blue, Satin White, and Signal Red.

Special paint systems are available when stringent specifications must be met, including corrosive environments involving acids, salt water, extreme climates, and other demanding locations.

WINDING DESIGN

Special starting and running requirements in both torque and speed properties can be designed and produced in-house, including:

- Split phase
- Cap Start Induction Run (CSIR)
- Cap Start Cap Run (CSCR)
- Permanent Split Capacitor (PSC)
- Three phase
- Integrated VVVF drive.

Details of winding options are available on page 23.

Other winding feature options also include:

- Multi-speed designs
- 2, 4, 6, 8 & 12 pole (3000 – 500 r/min)
- Non-standard voltages and frequencies
- Intermittent duty windings
- Torque and high slip windings.

Most motors come standard with F class insulation and B class (80K) temperature rise. Alternatives are also available.

PROTECTION AND COOLING

Ingress protection comes standard as IP44. (Ratings up to IP56 are available.)

Electrical overload protection can be designed as either auto reset (internal and external) or manual reset (external).

The motor cooling method is an important consideration in relation to both ingress and overload protection. Cooling options include:

- Totally enclosed fan cooled (TEFC) - standard
- Drip proof fan cooled (DPFC)
- Totally enclosed surface cooled (TESC)
- Totally enclosed air over motor (TEAOM).

BUILT TO STANDARD

The main dimensions and rated outputs of CWTC motors generally conform to Australian standard AS1359, international standard IEC 600072 (metric frames) and British standard BS2048 (imperial B56 frame).

APPLICATIONS

Regal Australia's knowledge and experience in motor design covers many common industrial applications. Along with our stocked CWT general purpose range, the CWTC range offers a ready solution to numerous applications in a variety of different industries. Below is a collection of application examples (further details on many of these are outlined in this catalogue).



Cement Mixers



Compressors



Floor Polishers



Brick Saws



Sewage Aeration

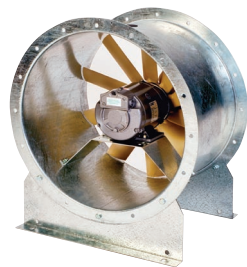

Centrifual & Axial Fans



Pool & Spa Pumps



Grain Feeders



Two Speed Saws



Shearers Grinders



Hydraulic Hoist



General Purpose

THE EXTENSIVE LIST OF APPLICATIONS ALSO INCLUDES:

- Industrial washing machines
- Farming equipment
- Wood lathes
- Gearboxes
- Refrigerated containers
- Evaporative coolers
- Materials handling
- Catering equipment
- Drill presses
- Brake motors
- Speedmaster integral motor-drive
- plus many more.

SPEEDMASTER

SPEEDMASTER INTEGRAL MOTOR-DRIVE

Regal Australia's Speedmaster represents the world's first truly integrated Motor-Variable Frequency Drive unit. It combines the reliability of a standard 3 phase motor, with a 240V AC single phase VVVF drive encapsulated in a conventional motor size, capitalising on the flexible mechanical design of traditional CWT motors.

The Speedmaster series is available with a rated output power from 0.37kW to 1.5kW and a frequency range of 20Hz to 60Hz. Motors can be programmed to match the torque/speed requirements of any customer's application.



FEATURES

- Simple speed control knob for easy use - no programming required
- Single phase 220-240V 50/60Hz supply
- Electronic variable speed
- Overload protection
- Optional remote control and electronic isolation/advanced control supply system
- Savings on installation costs - no additional wiring is needed
- Compact TEFC design
- IP55 ingress protection
- Standard with 2 metre flex & plug
- Reversible

MOTOR SPECIFICATIONS

Regal Australia Product Code	Output kW	Full Load AMPS	Standard Rotation Direction	Speed RPM		Torque	Frame	Mount	Flex & Plug Rating	Length L [mm]
				min	max					
CWTC4012A1	0.75	7.1	ACW	550	1720	Constant	B56	B3	10A	293
CWTC4017A1	0.75	7.1	CW	550	1720	Constant	D80	B5	10A	296
CWTC4009A1	0.75	7.1	CW	550	1720	Constant	D80	B14A	10A	276
CWTC4013A1*	1.50	14.0	CW	800	1700	Constant	D90	B3	15A	360
CWTC4018A1*	1.50	14.0	CW	800	1700	Constant	D90	B5	15A	360
CWTC4010A1*	1.50	14.0	CW	800	1700	Constant	D90	B14A	15A	335
CWTC4012B1	0.75	7.1	CW	570	1720	Variable	B56	B3	10A	293
CWTC4013B1	1.50	14.0	CW	570	1700	Variable	D90	B3	15A	360

*Minimum 30Hz.
Output kW relates to max speed.
Motor dimensions page 18.



EVAPORATIVE COOLER

EVAPORATIVE COOLER MOTORS

Regal Australia's Evaporative Cooler series is a trusted and proven design for reliability and performance within the cooler industry. The motors are designed locally for the toughest Australian conditions.

Motor designs are dual or variable speed to suit a variety of air movement applications. Flexibility in the design process enables motors to be manufactured to customer specified designs. Standard motors are single phase. Other power ratings and three phase versions are available on request.

FEATURES

- Resilient mount
- Fully interchangeable with other brands
- Drip proof with internal cooling fan
- In-winding auto-reset thermal overload protection
- Efficient 240V 50Hz single phase PSC winding design
- Low noise
- B56 motor frame
- Reversible
- Full protection against corrosion of motor and cradle (zinc plated)

MOTOR SPECIFICATIONS

Regal Australia Product Code	Model	Input kW	Full Load AMPS	Speed RPM	Variable or Dual Speed	Standard Rotation Direction	Dimensions		
							L [mm]	L1 [mm]	L2 [mm]
CWTC4031A	M550	0.80	3.3	1360	Variable	ACW	237	218	25.4(10)
CWTC4031B	M750	1.00	4.1	1400	Variable	ACW	263	244	50.8(20)
CWTC4031C	M550	0.66	2.7/1.5	1380/900	Dual	ACW	237	218	25.4(10)
CWTC4031D	M750	0.85	3.7/2.2	1380/900	Dual	ACW	263	244	50.8(20)
CWTC4031E	M1100	1.20	5.2/3.5	1400/1050	Dual	ACW	288	269	76.2(30)
CWTC4031F	M1500	1.70	7.5/5.3	1400/1090	Dual	ACW	288	269	76.2(30)

When used with speed varying device, speed is variable from the rated speed down to a recommended minimum of 600r/min. For CWTC4031B and CWTC4031F the front endshield is slotted through 360° (all others are slotted through 120°). Motor dimensions page 18.

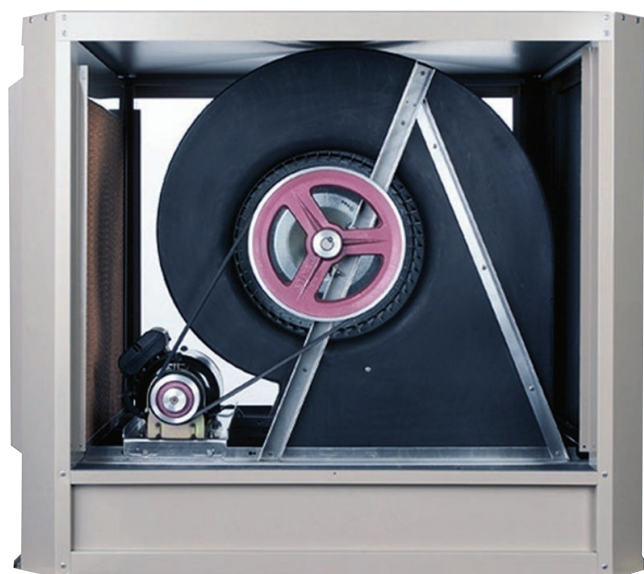

COMPRESSOR

COMPRESSOR DUTY MOTORS

The Regal Australia Compressor series is designed and manufactured to meet demanding applications where the need for high starting performance, reliability, and flexibility is paramount.

Compressor motors are available in single phase with rated output powers available from 1.65kW to 2.4kW.

FEATURES

- Heavy duty centrifugal switch
- High starting torque CSCR design
- TEFC or DPFC cooling designs
- Rolled steel case with steel B56 base
- Manual reset thermal overload protection
- Easy 240V single phase connection via supplied lead from top cap box.

MOTOR SPECIFICATIONS

Regal Australia Product Code	Output kW	Full Load AMPS	Speed RPM	Standard Rotation Direction	Reversible	Cooling	3 Core Lead	Length L [mm]
CWTC3971B	1.65	9.0	2820	ACW	YES	TEFC	0.58m / 10A	278
CWTC3971E	2.40	13.6	2840	ACW	YES	DPFC	0.88m / 15A	304

Motor dimensions page 18.



BRICKSAW

BRICKSAW MOTORS

The custom-built Regal Australia Bricksaw series are specially designed to have higher torque characteristics needed for demanding saw applications. Regal Australia Bricksaw motors have a proven track record in the industry and are renowned for their reliability and premium quality.

FEATURES

- High starting torque CSCR design
- Motor-mounted heavy duty on/off switch
- 240V single phase
- 2 metre flex & 10 Amp clear plug supplied
- Manual reset overload protection
- IP55 protection against dust and water ingress
- Extra rating label inside capacitor box for easy identification

MOTOR SPECIFICATIONS

Regal Australia Product Code	Output kW	Full Load AMPS	Speed RPM	Standard Rotation Direction	On/Off switch position
CWTC3637D	1.7	9.6	2880	CW	RHS
CWTC3766B	1.7	9.6	2880	ACW	LHS

The rotation of these motors is fixed for safety reasons.
Motor dimensions page 18.



CEMENT MIXER

CEMENT MIXER / SPLIT PHASE MOTORS

Regal Australia's general purpose Split Phase motor series is ideal for domestic, commercial and light industrial applications. Common uses include cement mixers, drill presses and light duty machinery.

This single phase workhorse comes standard in 0.56kW, and is available in other rated output powers on request. With motors in the field as old as 50 years this well proven long standing design performs day in day out without missing a beat.

FEATURES

- Double pole on/off switch
- Comes standard with flex & clear plug fitted
- TEFC cooling
- IP44 protection against dust and water ingress (IP55 available upon request)
- Rolled steel case with B56 base
- Manual reset thermal overload protection
- 240V Single phase Split Phase winding design

MOTOR SPECIFICATIONS

Regal Australia Product Code	Output kW	Full Load AMPS	Speed RPM	Standard Rotation Direction	Reversible	Lead Length [m]	T/box position	Base	Length L [mm]
CWTC3572A	0.56	5.3	1420	CW	YES	3.0	Top	Steel	251
CWTC3572E	0.56	5.3	1420	CW	YES	0.3	Top	Aluminium	264
CWTC3705C	0.56	5.3	1420	ACW	YES	0.3	RHS	Aluminium	264

Motor dimensions page 19.



FAN MOTORS

FAN SERIES MOTORS

Specifically designed for fan applications, the Fan series is available in both single and three phase versions, with rated output powers from 0.37kW to 0.75kW. Motors are either a fixed or variable speed design to suit a variety of air movement applications.

Flexibility in our design process enables us to manufacture motors to suit your needs.

FEATURES

- Single and three phase models
- Efficient PSC winding design (single phase models)
- IP55 protection against dust and water ingress
- Reversible
- Low noise
- In-winding auto-reset thermal overload protection (single phase models)
- TEFC or TEAOM cooling options

MOTOR SPECIFICATIONS

Regal Australia Product Code	Output kW	Connection	Full Load AMPS	Speed		Standard Rotation Direction	Length L [mm]	Design
				RPM	Variation			
CWTC3626A1	0.37	1Ø	2.9	1410	Fixed	CW	234	TEAOM
CWTC3626D1	0.37	1Ø	2.5	930	Fixed	CW	234	TEAOM
CWTC3626B1	0.56	1Ø	3.5	1420	Fixed	CW	234	TEAOM
CWTC3626C1	0.75	1Ø	4.7	1420	Fixed	CW	234	TEAOM
CWTC3626P1	0.75/0.60*	1Ø	4.4/3.6*	1380/1410*	Variable	CW	247	TEAOM
CWTC3626H	0.37	3Ø	1.1	1400	Fixed	CW	234	TEAOM
CWTC3626J	0.72	3Ø	1.7	1400	Fixed	CW	234	TEAOM

When used with a speed varying device, the speed is variable from the rated speed down to a recommended 600r/min minimum.

* Values correspond with Ducted/Free air movement applications. (See diagrams below.)

Motor dimensions page 19.

Ducted

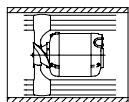
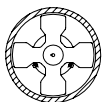

Free

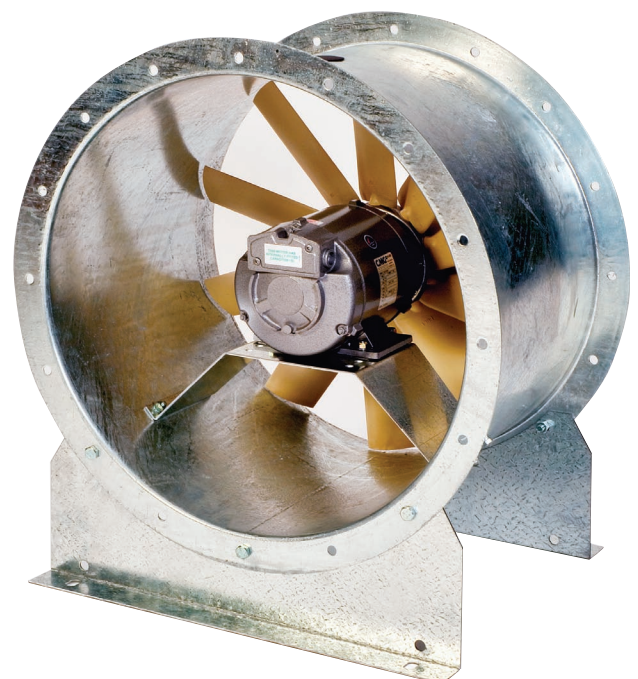
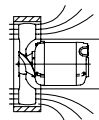
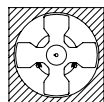

GRAIN FEEDER

GRAIN FEEDER MOTORS

Specifically designed for feeder applications, the Grain Feeder series is available in both single and three phase versions, with rated output powers from 0.37kW to 0.75kW.

Regal Australia's rolled steel body is ideal for this application, as it avoids the build up of harmful contaminants that occurs on finned body motors. Porous drain plugs fitted allow any moisture or condensation to escape, avoiding any possibility of water build up inside the motor.

FEATURES

- Proven to last
- Smooth rolled steel case
- High starting torque CSCR winding design (single phase)
- TEFC cooling
- IP55 protection against dust and water ingress
- NEMA "oil burner" flange
- Manual reset thermal overload protection (single phase models)

MOTOR SPECIFICATIONS

Regal Australia Product Code	Output kW	Connection	Full Load AMPS	Speed RPM	Standard Rotation Direction	Reversible	Voltage
CWTC3910A	0.37	1Ø	2.5	1380	ACW	Yes	240
CWTC3910B	0.56	1Ø	3.3	1390	ACW	Yes	240
CWTC3910N	0.56	1Ø	3.5	2720	ACW	Yes	240
CWTC3910C	0.75	1Ø	4.5	1410	ACW	Yes	240
CWTC3910H	0.72	3Ø	1.7	1400	ACW	Yes	415

Single phase models are fitted with a 0.69m flex & plug.
Motor dimensions page 19.



SEWAGE AERATION

SEWAGE AERATION MOTORS

The purpose built Sewage Aeration series is a Regal Australia original and remains the dominant market leader. The motor boasts a proven track record within the industry for reliability and premium quality.

The special hollow stainless steel shaft design and protective coating gives a perfectly adapted motor for this application.

FEATURES

- Proudly designed in Australia
- Special marine grade epoxy coating
- IP56+ protection against water and dust ingress
- 240V single phase
- Efficient PSC winding design
- TESC cooling
- Shaft and all mounting attachments are stainless steel

MOTOR SPECIFICATIONS

Regal Australia Product Code	Output kW	Full Load AMPS	Speed RPM	Standard Rotation Direction	Flex	Capacitor
CWTC3635D	0.12	1.00	2925	ACW	3 core	Internal, high temp
CWTC3635E	0.12	1.00	2925	ACW	4 core, with quick connectors	External

Motor dimensions page 19.



GENERAL PURPOSE

GENERAL PURPOSE MOTORS

The popular Regal Australia General Purpose series motor is a strong performer, ideally suited for most general applications. The series is designed to suit domestic, commercial and industrial applications. With no wiring necessary, it is simple and convenient to use.

Available in single phase with rated output powers from 0.37kW to 1.5kW continuous duty.

FEATURES

- High starting torque CSCR winding design
- TEFC cooling
- IP44 protection against dust and water ingress (IP55 available upon request)
- Heavy Duty rolled steel case with B56 base
- Manual reset thermal overload protection
- 240V single phase with 2 metre flex & clear 10A plug standard

MOTOR SPECIFICATIONS

Regal Australia Product Code	Output kW	Full Load AMPS	Speed RPM	Standard Rotation Direction	Reversible	Shaft Size D	L [mm]	L1 [mm]	L2 [mm]
CWTC3703A	0.37	2.5	1380	CW	YES	5/8"	275	47.5	69.8
CWTC3703B	0.56	3.3	1390	CW	YES	5/8"	275	47.5	69.8
CWTC3703C	0.75	4.5	1410	CW	YES	5/8"	275	47.5	69.8
CWTC3708A	1.10	6.0	1420	CW	YES	3/4"	317	52.5	61.5
CWTC3708B	1.50	8.2	1430	CW	YES	3/4"	317	52.5	61.5

Motor dimensions page 19.



PUMPING Motors

PUMPING MOTORS

Specifically designed for a variety of pump applications, Regal Australia's Pump series is available in both single and three phase versions, with rated output powers from 0.75kW to 2.0kW.

Our flexible design process gives us the capability of manufacturing motors with special flange and shaft arrangements to meet specific customer requirements.

Swimming pool and spa motors are certified to the latest and most stringent standards (AS/NZS 60335).

FEATURES

- Australian Made
- Full length stainless steel shaft with protected screwdriver slot in rear
- Painted black as standard (other colours available on request)
- Overload protection
- Slimline single capacitor box
- IP44 protection against dust and water ingress (IP55 available upon request)
- Efficient 240V single phase PSC winding design

MOTOR SPECIFICATIONS

Regal Australia Product Code	Output kW	Full Load AMPS	Speed RPM	Standard Rotation Direction	Length L [mm]
CWTC3973A	0.75	4.4	2790	ACW	291
CWTC3973D	1.5	8.2	2840	ACW	304

Motor dimensions page 19.



BRAKE Motors

BRAKE MOTORS

Regal Australia offers a variety of light industrial Brake motors, available in both single and three phase versions, with rated output power from 0.37kW to 1.7kW.

Brake motors are designed for use in applications requiring rapid stopping, holding and position control. Any standard motor from our CWT range can be manufactured with an electro-magnetic brake fitted.

FEATURES

- Quality MAYR electro-magnetic DC brake fitted
- Compact design
- Fail safe design
- brake engages when power is interrupted
- Fast acting brake
- Self adjusting
- Manual hand release option available

MOTOR SPECIFICATIONS

Regal Australia Product Code	Output kW	Connection	Frame	Mounting	Brake Torque [NM]			Brake Torque (% of full load)			XL
					Min	Norm.	Max	Min	Norm.	Max	
CWTB240371	0.37	1Ø	B56	B3	1.4	4	5	55%	160%	200%	45
CWTB24037F1	0.37	1Ø	D71	B5	1.4	4	5	55%	160%	200%	45
CWTB240751	0.75	1Ø	B56	B3	2.8	8	10	55%	160%	200%	58
CWTB24075F1	0.75	1Ø	D80	B5	2.8	8	10	55%	160%	200%	58
CWTB241701	1.7	1Ø	D90	B3	5.5	16	20	50%	140%	175%	93
CWTB24170E1	1.7	1Ø	D90	B3/B5	5.5	16	20	50%	140%	175%	93
CWTB340371	0.37	3Ø	B56	B3	1.4	4	5	55%	160%	200%	20
CWTB34037F1	0.37	3Ø	D71	B5	1.4	4	5	55%	160%	200%	20
CWTB340751	0.72	3Ø	B56	B3	2.8	8	10	55%	160%	200%	20
CWTB34075F1	0.72	3Ø	D80	B5	2.8	8	10	55%	160%	200%	20
CWTB341501	1.5	3Ø	D90	B3	5.5	16	20	55%	160%	200%	55
CWTB34150FHR1*	1.5	3Ø	D90	B5	5.5	16	20	55%	160%	200%	55

XL = Extra motor length to standard CWT motors on page 21.

* Comes standard with hand release.

Not all brake motors are stocked, minimum order quantities may apply.

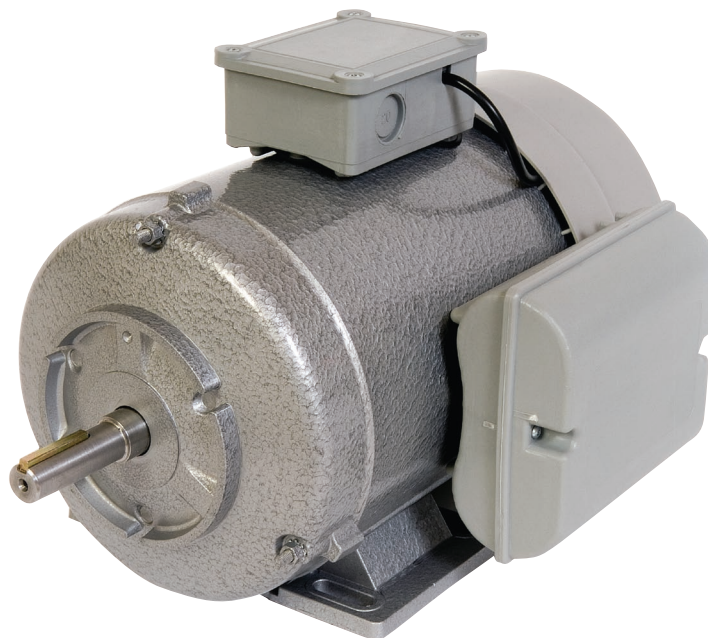

SPARE PARTS

Spare parts listed are used on standard CWT motors and many CWTC special application motors. For all other spare parts please contact your nearest Regal Australia office.

CAPACITORS & OVERLOADS



Regal Australia Product Code	Start Capacitor [μ F/volts]	Run Capacitor [μ F/volts]	Manual Reset Overload Part Number
CWT14075	-	-	887M-04
CWT22056	40-50/320	14/450	887M-06
CWT22075	50-63/320	20/450	887M-02
CWT22110	80-100/320	25/450	887M-18
CWT22150	108-130/250	25/450	887M-22
CWT22220	160-200/250	40/400	887M-16
CWT24037	31-40/320	12.5/450	887M-13
CWT24056	31-40/320	16/450	887M-06
CWT24075	63-80/320	20/450	887M-02
CWT24110	80-100/320	25/450	887M-04
CWT24150	100-125/250	25/450	887M-14
CWT24170	125-160/250	25/450	887M-14
CWT24220	125-160/250	25/450	887M-21
CWT26037	40-50/320	14/450	887M-13
CWT26075	80-100/250	16/450	887M-09
CWT26110	100-125/250	25/450	887M-18

Note: All start capacitors are fitted with discharge resistors.

BASES



Regal Australia Product Code	Description
794-55730	B56 aluminium base
794-554911	D90 aluminium base
794-52190	B56 pressed steel base
794-52110	D90 pressed steel base

FANS



Regal Australia Product Code	Description
788-555617A	Black plastic 17mm bore fan

COWLS



Regal Australia Product Code	Description
792-5448BH	Black plastic cowl
792-5450GH	Grey plastic cowl (std on brake motors)

CAPACITOR BOXES



Regal Australia Product Code	Description
800-50640B	Black capacitor box base
800-50650B	Black capacitor box lid

TERMINAL BOXES



Regal Australia Product Code	Description
800-5090TB	Black plastic terminal box base overload
800-50910B	Black plastic terminal box lid
800-50900B	Black plastic terminal box base

DIMENSIONS

COMMON CWTC DIMENSIONS

(Unless shown otherwise)

With B56 Base Aluminium

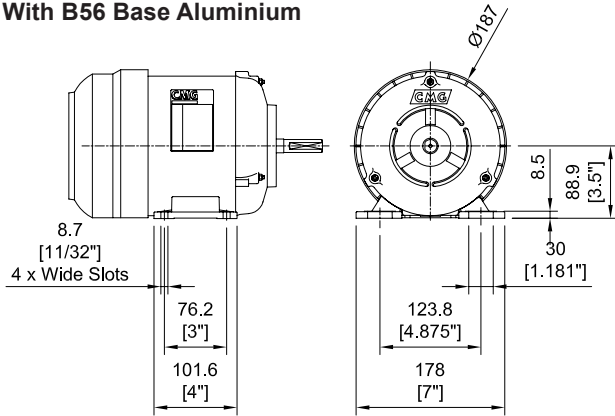

D90 Base Aluminium

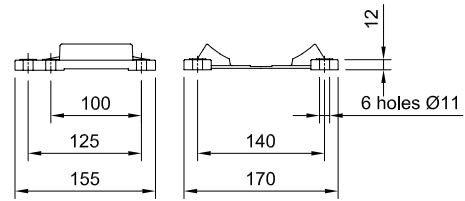

SPEEDMASTER

(See standard product dimensions page 21 for C, D and E)

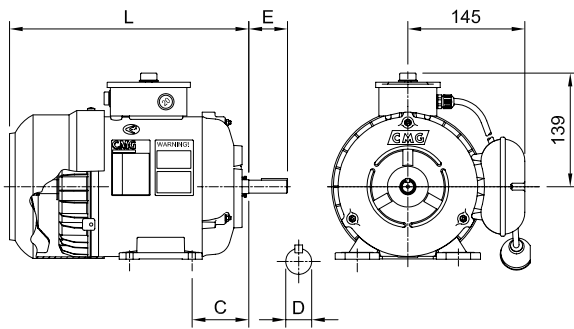

COMPRESSOR

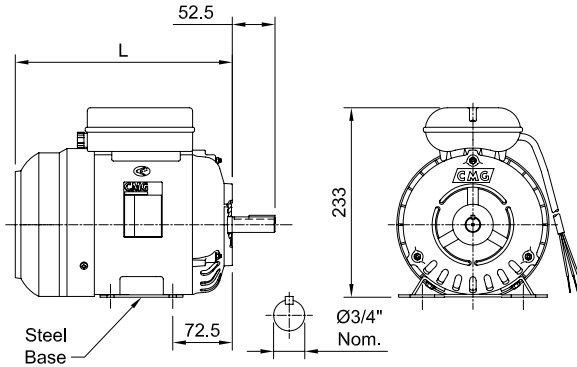

EVAPORATIVE COOLER

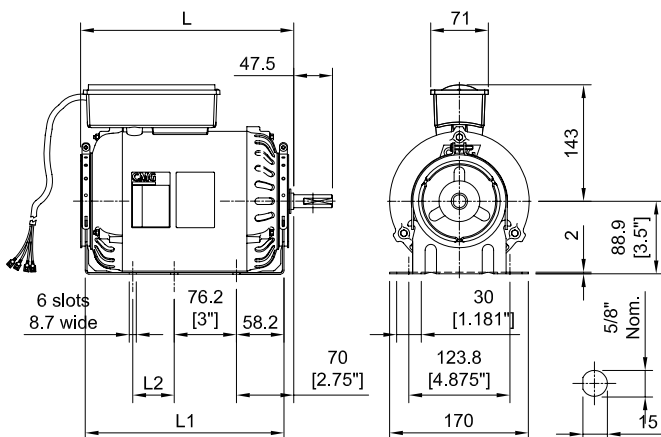

BRICKSAW

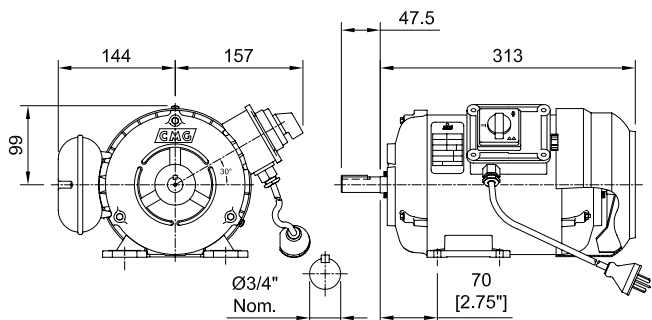

CEMENT MIXER

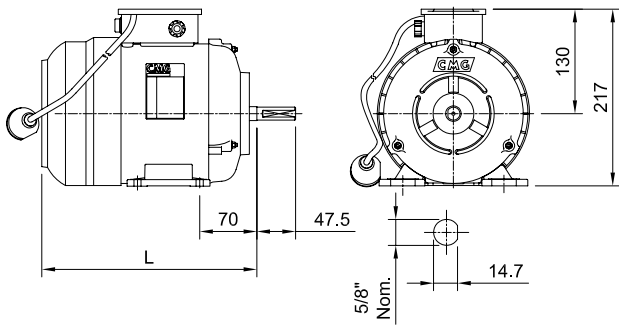

SEWAGE AERATION

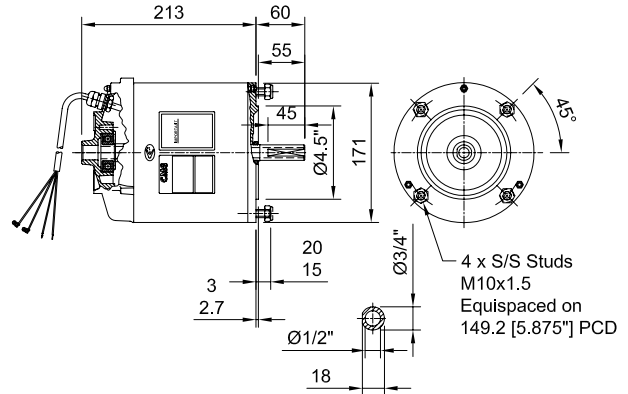

FAN SERIES (CWTC3626 models)

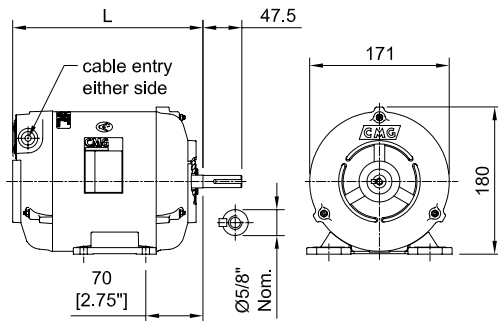

GENERAL PURPOSE

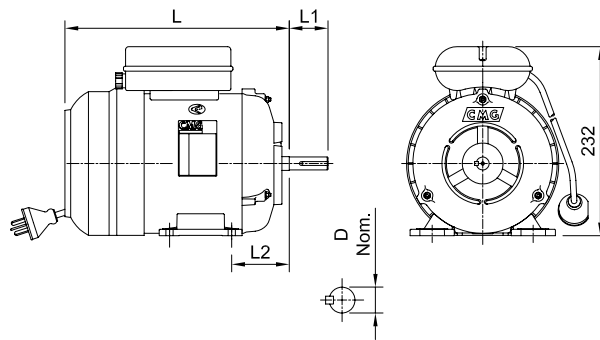

GRAIN FEEDER

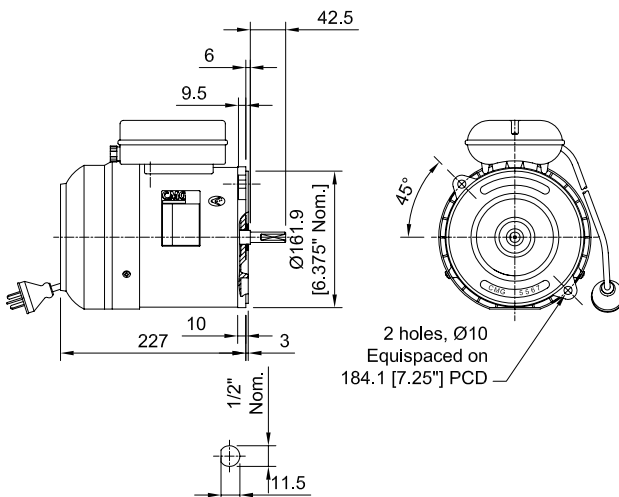

PUMPING

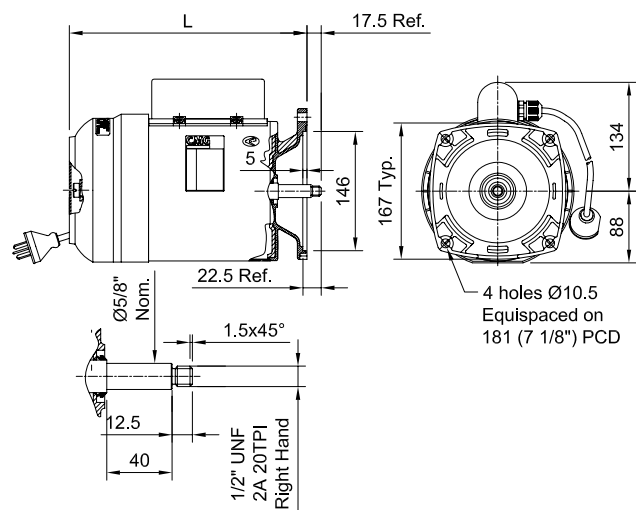

For more detailed drawings please contact your nearest Regal Australia office
Call us on 1300 888 853 or visit www.regalaustralia.com.

Regal Australia Product Code*	Motor Frame			Speed	Efficiency [%]	Power Factor	Current		Torque			Weight of Foot Mount Motor [kg]
	kW	B3	B5				Full Load [A]	Locked Rotor	Full Load [Nm]	Locked Rotor	Break Down	
Single phase - Split phase - 240V 50Hz												
1500 r/min = 4 poles												
CWT14075 ¹⁾	0.75	B56	D80	1425	67.0	0.72	6.5	6.5	5.0	1.5	2.0	14
Single phase - CSCR - 240V 50Hz												
3000 r/min = 2 poles												
CWT22037	0.37	B56	D71	2770	66.8	0.97	2.4	4.1	1.3	2.3	1.9	10
CWT22056F	0.56		D71	2770	68.7	0.99	3.5	3.7	1.9	1.9	1.6	12
CWT22075	0.75	B56		2790	72.9	0.98	4.4	3.5	2.6	1.8	1.8	13
CWT22110	1.1	B56	D80	2850	75.9	0.97	6.2	4.7	3.7	2.1	1.8	17
CWT22150 ¹⁾	1.5	D90	D90	2840	79.2	0.96	8.2	5.1	5.0	2.0	2.1	19
CWT22220 ¹⁾	2.2	D90	D90	2870	80.9	0.97	11.6	6.1	7.3	1.7	2.5	21.5
1500 r/min = 4 poles												
CWT24037F	0.37		D71	1380	66.4	0.97	2.4	3.8	2.5	2.4	1.6	9
CWT24056F	0.56		D80	1390	73.0	0.97	3.3	3.8	3.8	1.7	1.7	12
CWT24075F	0.75		D80	1410	75.7	0.96	4.3	4.9	5.1	2.2	2.1	13
CWT24110	1.1	D90	D90	1420	79.3	0.97	6.0	5.1	7.4	2.4	2.0	17
CWT24150	1.5	D90	D90	1430	79.6	0.97	8.2	5.4	10.0	2.0	1.9	21
CWT24170 ¹⁾	1.7	D90	D90	1420	79.5	0.97	9.3	5.3	11.5	2.1	2.0	22
CWT24220 ¹⁺²⁾	2.2	D90	D90	1400	77.3	0.94	12.4	4.8	14.9	1.9	1.8	22
1000 r/min = 6 poles												
CWT26037	0.37	B56	D80	930	66.4	0.96	2.4	3.9	3.8	1.8	1.6	12
CWT26075	0.75	D90	D90	950	71.9	0.82	5.3	4.7	7.5	2.4	2.3	22
CWT26110 ¹⁺²⁾	1.1	D90	D90	950	69.3	0.86	7.7	4.4	11.0	2.0	2.0	22
Three phase - 415V 50Hz												
3000 r/min = 2 poles												
CWT32075	0.72	B56	D80	2760	74.5	0.79	1.70	5.3	2.5	3.5	3.0	13
1500 r/min = 4 poles												
CWT34037	0.37	B56		1400	68.3	0.69	1.10	4.7	2.5	3.1	2.8	9
CWT34075	0.72	B56	D80	1400	77.4	0.77	1.70	5.7	4.9	3.6	2.8	12
1000 r/min = 6 poles												
CWT36018	0.18	B56		940	64.5	0.55	0.70	3.8	1.9	2.9	3.2	9
CWT36037	0.37	B56		930	71.1	0.64	1.15	4.1	3.8	3.1	3.3	11
CWT36056	0.56	B56	D80	920	72.4	0.68	1.60	3.8	5.8	2.8	2.5	12
500 r/min = 12 poles												
CWT3C018*	0.18	B56	D71	450	49.8	0.46	1.10	2.0	3.8	2.3	2.4	15.5

¹⁾ Class F temperature rise (100K).

²⁾ Use DPFC cooling, all others use TEFC.

* Product codes shown are for B3 versions. For B5 versions add suffix 'F', for B3/B5 versions add suffix 'E', and for B14 versions add suffix 'N' (domed endshield)

DIMENSIONS

Standard Products

FOOT MOUNT B3 (IM1001)

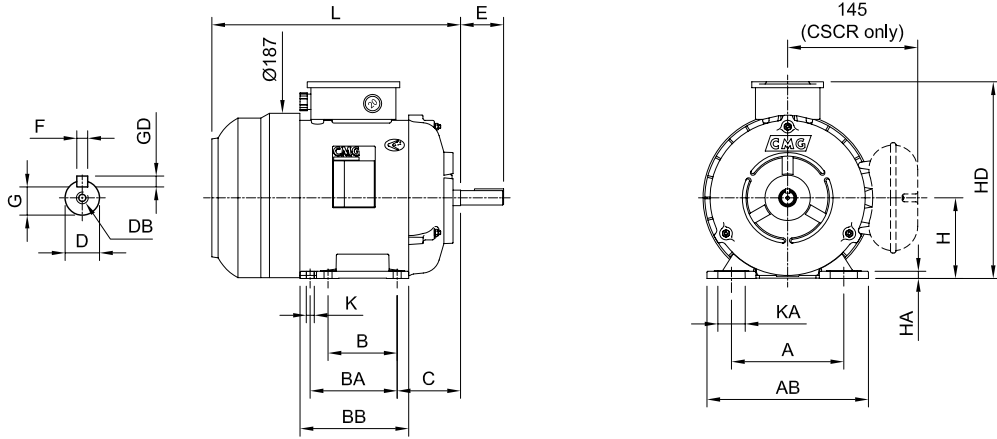

Motor Frame	A	AB	B	BA	BB	C	D	DB	E	F	GD	G	H	HA	HD	K	KA	L	
B56	-5/8"	123.8	182	76.2	-	101.6	69.8	15.875	-	47.6	4.76	4.76	13.10	88.9	8.5	219	8.7	30	274
D90	-24	140	180	100	125	155	56	24	M8	50	8	7	20	90	12	220	10	10	327

LARGE FLANGE MOUNT B5 (IM3001)

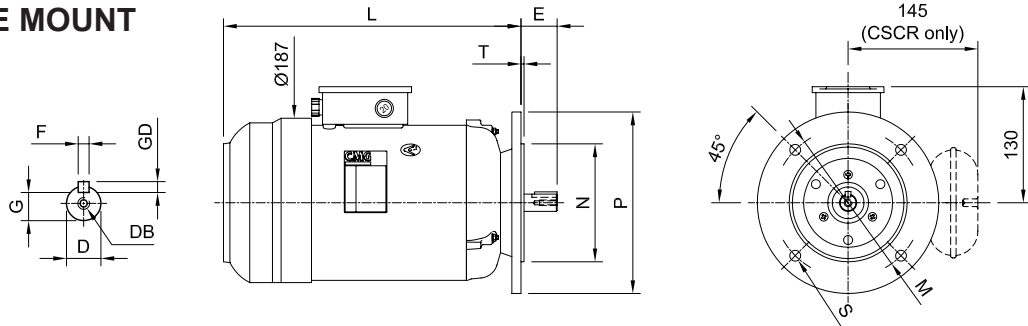

Motor Frame	D	DB	E	F	GD	G	L	M	N	P	S	T	
D71	-14	14	M5	30	5	5	11.0	277	130	110	160	10	3.5
D80	-19	19	M6	40	6	6	15.5	277 ¹⁾	165	130	200	12	3.5
D90	-24	24	M8	50	8	7	20.0	327	165	130	200	12	3.5
B56	-5/8"	15.875	-	47.6	4.76	4.76	13.10	277	139.7	120.65	165.1	8.7	3.0
NEMA 56	-5/8"	15.875	-	47.6	4.76	4.76	13.10	277	149.2	114.30	165.1	10	3.0

SMALL FLANGE (FACE) MOUNT B14 (IM3601)

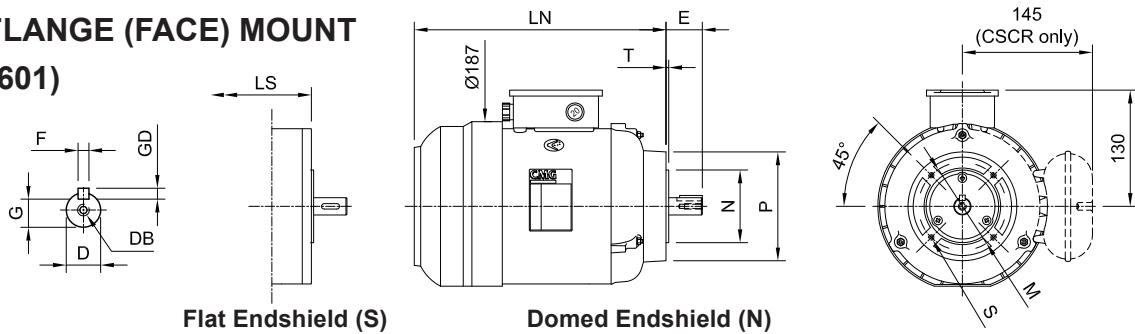

Motor Frame	D	DB	E	F	GD	G	LN	LS	B14A					B14B					
									M	N	P	S	T	M	N	P	S	T	
D71	-14	14	M5	30	5	5	11.0	277	227	85	70	105	M6	2.5	115	95	140	M8	3.0
D80	-19	19	M6	40	6	6	15.5	277	253	100	80	120	M6	3.0					
D90	-24	24	M8	50	8	7	20.0	327	-	115	95	140	M8	3.0					

TECHNICAL DATA

OPERATING PARAMETERS

Special application CWTC and standard CWT series motors are designed to the following parameters:

- Continuous duty (S1)
- Three phase 415V STAR / 240V DELTA, 50Hz power supply
Single phase 240V, 50Hz
- Ambient temperatures up to 40°C
- Installation at altitudes up to 1000 metres.

Performance data is based on these parameters and may need adjustment for different conditions.

MATERIALS AND CONSTRUCTION

Materials used in the construction of CWTC and CWT series motors include:

- Aluminium endshield
- Rolled steel body
- Polypropylene copolymer fan and fan cowl
- 20% glass filled polypropylene terminal and capacitor cover
- Cast aluminium base (pressed steel versions are available).

ROTOR BALANCING

Rotors have been balanced fitted with half key, to a commercial level. Special balancing can be performed on request.

BEARINGS

Regal Australia CWT standard series motors are provided with high quality shielded bearings (ZZ), prepacked with grease. Bearings with full contact neoprene seals (DDU or 2RS) are available for enclosure ratings such as IP55 and are fitted to CWTC special application motors.

Bearings are lubricated with lithium based rolling contact bearing grease and are suitable for operation within the ambient temperature range of -20°C to +40°C. Low or high temperature grease is available on request.

ROTATION

Standard single phase motors are supplied to give clockwise rotation, as viewed from drive end. They can easily be reconnected to anti-clockwise rotation by interchanging two leads in the terminal box. Rotation of special application CWTC motors vary. See relevant page for details.

IP RATING

IP ratings for the CWT standard range is IP44 (up to IP56 is available). For CWTC motors see relevant pages.

TECHNICAL DATA

WINDING CONFIGURATIONS

Split phase

Split phase motors are single phase. The starting winding has **less turns** and smaller wire size than the running winding. This gives a relatively low locked rotor torque and high locked rotor current. The starting winding is cut out by a centrifugal switch at the appropriate speed.

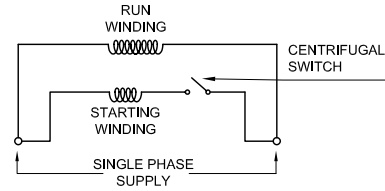

Capacitor start induction run (CSIR)

CSIR motors are similar to split phase but have a capacitor connected in series with the starting winding. This gives a higher locked rotor torque for less current than a split phase motor.

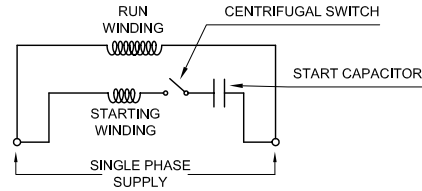

Capacitor start capacitor run (CSCR)

CSCR motors have two capacitors connected in series with the auxiliary winding. One capacitor of low value (run capacitor) is permanently connected. The second capacitor of high value (start capacitor) is connected in parallel with the run capacitor during the start up period. This motor is more efficient than CSIR.

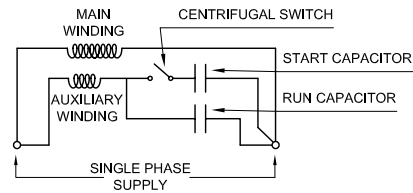

Permanent split capacitor (PSC)

For PSC motors one capacitor is permanently connected in series with the auxiliary winding. This gives a low locked rotor torque and current and is used mainly for driving fans and some pumps.

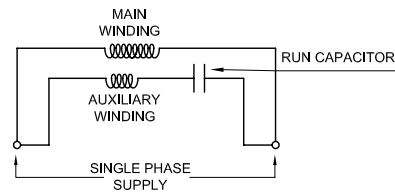

Three phase

Three phase motors have three balanced windings displaced by 120 electrical degrees producing a rotating field without switch or capacitor components. The windings produce relatively high locked rotor torques.

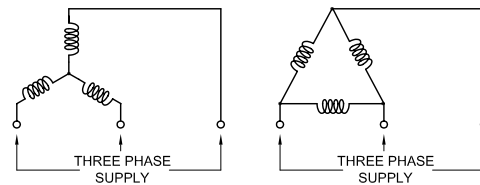

▲ Star Connection

▲ Delta Connection

HEAD OFFICE

19 Corporate Ave / PO Box 2340
Rowville VIC 3178 AUSTRALIA

Tel: +61 (0)3 9237 4000
Fax: +61 (0)3 9237 4010

AUSTRALIA

Sales
1300 888 853
Drives Technical Support
1800 676 722
www.regalaustralia.com
www.regalbeloit.com

REGAL BELOIT AUSTRALIA Pty Ltd
ABN 61 122 303 084

VICTORIA

19 Corporate Avenue
Rowville VIC 3178
Tel: +61 (0)3 9237 4040
Fax: +61 (0)3 9237 4050

NEW SOUTH WALES

SYDNEY
6-7 Bushells Place
Wetherill Park NSW 2164
Tel: +61 (0)2 8781 3100
Fax: +61 (0)2 8781 3131

NEWCASTLE

3/11 Kinta Drive
Beresfield NSW 2320
Tel: +61 (0)2 4028 6407
Fax: +61 (0)2 4028 6437

NEW ZEALAND

CMG Electric Motors (NZ) Ltd
18 Jomac Place
Avondale Auckland
NEW ZEALAND
Tel: +64 9820 3550
Fax: +64 9820 8504

SINGAPORE

CMG Electric Motors
(Asia Pacific) Pte Ltd
12 Tuas Loop 637346
SINGAPORE
Tel: +65 6863 3473
Fax: +65 6863 3476

QUEENSLAND

BRISBANE
7 Mahogany Court
Willawong QLD 4110
Tel: +61 (0)7 3246 3246
Fax: +61 (0)7 3246 3210

CAIRNS ("Service - Repairs - Sales")
2/159-161 Newell Street
Bungalow QLD 4870
Tel: +61 (0)7 4033 1109
Fax: +61 (0)7 4033 5553

MACKAY

Cnr. John Vella Drive & Connors Road
Paget, Mackay QLD 4740
Tel: +61 (0)7 4952 6244
Fax: +61 (0)7 4952 6277

THAILAND

FASCO Motors (Thailand) Limited
29/7-8 Bangkruay-Sainoi Road,
Bangkrang, Muang Nonthaburi
District Nonthaburi 11000 THAILAND
Tel: +66 2447 3300
Fax: +66 2447 3500

MALAYSIA

Regal Beloit (dba Torin dba CMG)
No. 6536A Jalan Bukit Kemuning
Batu 6, Seksyen 34
40470 Shah Alam, Selangor.
Tel: +60 3 51246157
Fax: +60 3 51211467

SOUTH AUSTRALIA

47 Research Road
Pooraka, SA 5095
Tel: +61 (0)8 8359 1321
Fax: +61 (0)8 8359 5675

WESTERN AUSTRALIA

21 Colin Jamieson Drive
Welshpool WA 6106
Tel: +61 (0)8 6253 3700
Fax: +61 (0)8 6253 3710

TASMANIA

115 Don Road
Devonport TAS 7310
Tel: +61 (0)3 6424 8574
Fax: +61 (0)3 6424 9393



REGAL